

Industrial Panel Line Drawings

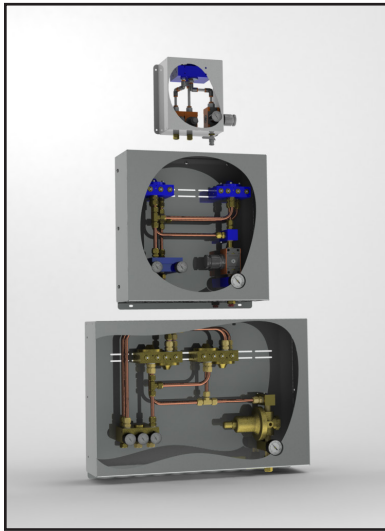

Model	# of Component Gases	# of Outlet Blends	Drawing
TM2B150	2	2	A
TM2B300	2	2	A
TM2B450	2	2	B
TM300	2	1	C
TM900	2	1	D
TMA950	2 or 3	1	E
TMA2000	2 or 3	1	E
TMA4000	2	1	E
TMA4000	3	1	F
TM950	2	1	G
TM2000	2	1	G
TM4000	2	1	G

Phone (888) 735-5607 or (406) 442-5153 • Email: info@mcDantim.com • Web Site: www.mcDantim.com

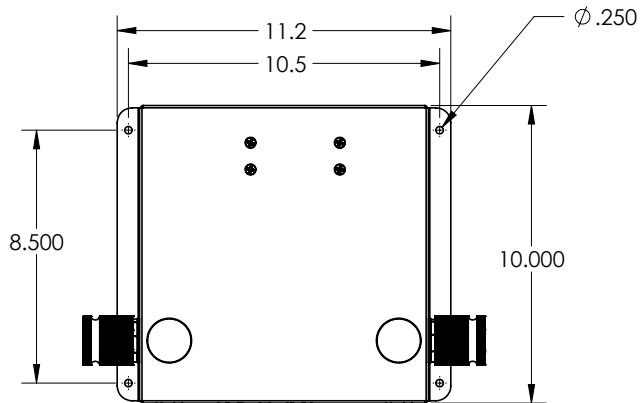

1/4" Female NPT
Pure Gas Inlets

1/4" Female NPT
Mixed Gas Outlets

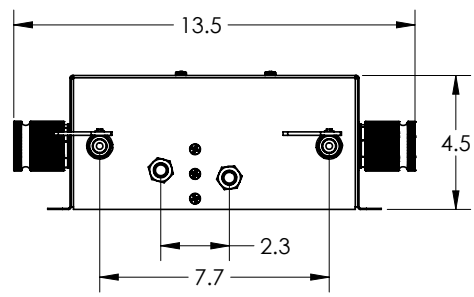

PROPRIETARY AND CONFIDENTIAL
THE INFORMATION CONTAINED IN THIS DRAWING IS THE SOLE PROPERTY OF MCDANTIM INC. ANY REPRODUCTION IN PART OR AS A WHOLE WITHOUT THE WRITTEN PERMISSION OF MCDANTIM INC IS PROHIBITED.

		UNLESS OTHERWISE SPECIFIED:	NAME	DATE
		DIMENSIONS ARE IN INCHES	DRAWN	TRA
		TOLERANCES:	CHECKED	9/16/15
		FRACTIONAL ± 1/32	ENG APPR.	
		ANGULAR: MACH ± .01	MFG APPR.	
		TWO PLACE DECIMAL ± .005	Q.A.	
		INTERPRET GEOMETRIC TOLERANCING PER: Y14.5M-1994	COMMENTS:	
		MATERIAL		
NEXT ASSY	USED ON	FINISH		
APPLICATION		DO NOT SCALE DRAWING		



TITLE:		
TM2B450-DIM		
SIZE	DWG. NO.	REV
A	TM2B450-DIM	
SCALE: 1:4	WEIGHT:	SHEET 1 OF 1

Drawing B

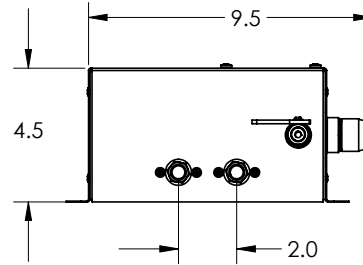
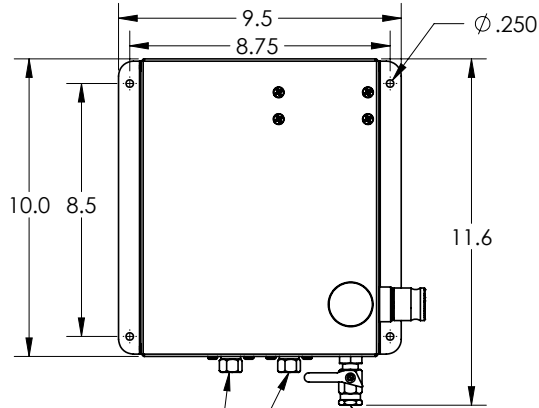

1/4" Female NPT
Pure Gas Inlets

1/4" Female NPT
Mixed Gas Outlet

Drawing C

PROPRIETARY AND CONFIDENTIAL
THE INFORMATION CONTAINED IN THIS DRAWING IS THE SOLE PROPERTY OF MCDANTIM INC. ANY REPRODUCTION IN PART OR AS A WHOLE WITHOUT THE WRITTEN PERMISSION OF MCDANTIM INC IS PROHIBITED.

		UNLESS OTHERWISE SPECIFIED:	NAME	DATE	 McDantim <small>GAS BLENDING TECHNOLOGIES</small>	
		DIMENSIONS ARE IN INCHES	DRAWN	TRA		9/21/15
		TOLERANCES:	CHECKED			
		FRACTIONAL ± 1/32	ENG APPR.			
		ANGULAR: MACH ± BEND ± TWO PLACE DECIMAL ±.01 THREE PLACE DECIMAL ±.005	MFG APPR.			
		INTERPRET GEOMETRIC TOLERANCING PER: Y14.5M-1994	Q.A.			
		MATERIAL	COMMENTS:			
NEXT ASSY	USED ON	FINISH	TITLE: TM300-DIM			
APPLICATION		DO NOT SCALE DRAWING				
			SIZE	DWG. NO.	REV	
			A	TM300-DIM		
			SCALE: 1:4	WEIGHT:	SHEET 1 OF 1	

5

4

3

2

1

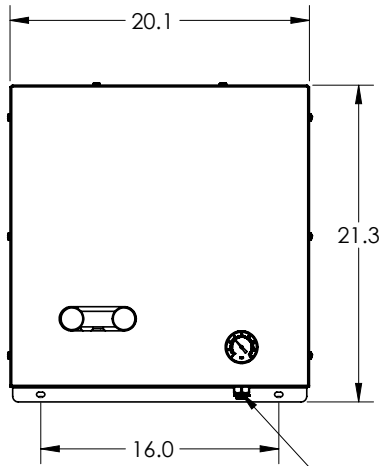

1/2" Female NPT
Mixed Gas Outlet

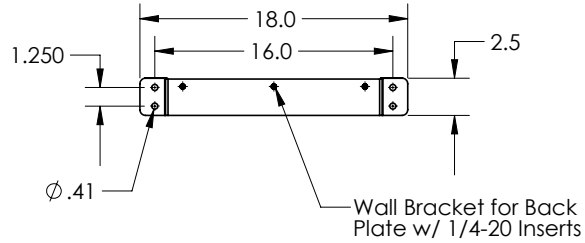

Wall Bracket for Back
Plate w/ 1/4-20 Inserts

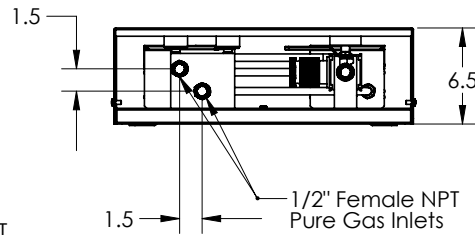

1/2" Female NPT
Pure Gas Inlets

PROPRIETARY AND CONFIDENTIAL
THE INFORMATION CONTAINED IN THIS DRAWING IS THE SOLE PROPERTY OF MCDANTIM INC. ANY REPRODUCTION IN PART OR AS A WHOLE WITHOUT THE WRITTEN PERMISSION OF MCDANTIM INC IS PROHIBITED.

		UNLESS OTHERWISE SPECIFIED:	NAME	DATE
		DIMENSIONS ARE IN INCHES	DRAWN	TRA
		TOLERANCES:	CHECKED	9/17/15
		FRACTIONAL ± 1/32	ENG APPR.	
		ANGULAR: MACH ± BEND ±	MFG APPR.	
		TWO PLACE DECIMAL ±.01	Q.A.	
		THREE PLACE DECIMAL ±.005	COMMENTS:	
		INTERPRET GEOMETRIC ANS		
		TOLERANCING PER: Y14.5M-1994		
		MATERIAL		
NEXT ASSY	USED ON	FINISH		
APPLICATION		DO NOT SCALE DRAWING		



TITLE:
TMA Panel-DIM

SIZE	DWG. NO.	REV
A	TMA Panel-DIM	
SCALE: 1:8	WEIGHT:	SHEET 1 OF 1

Drawing E

5

4

3

2

1

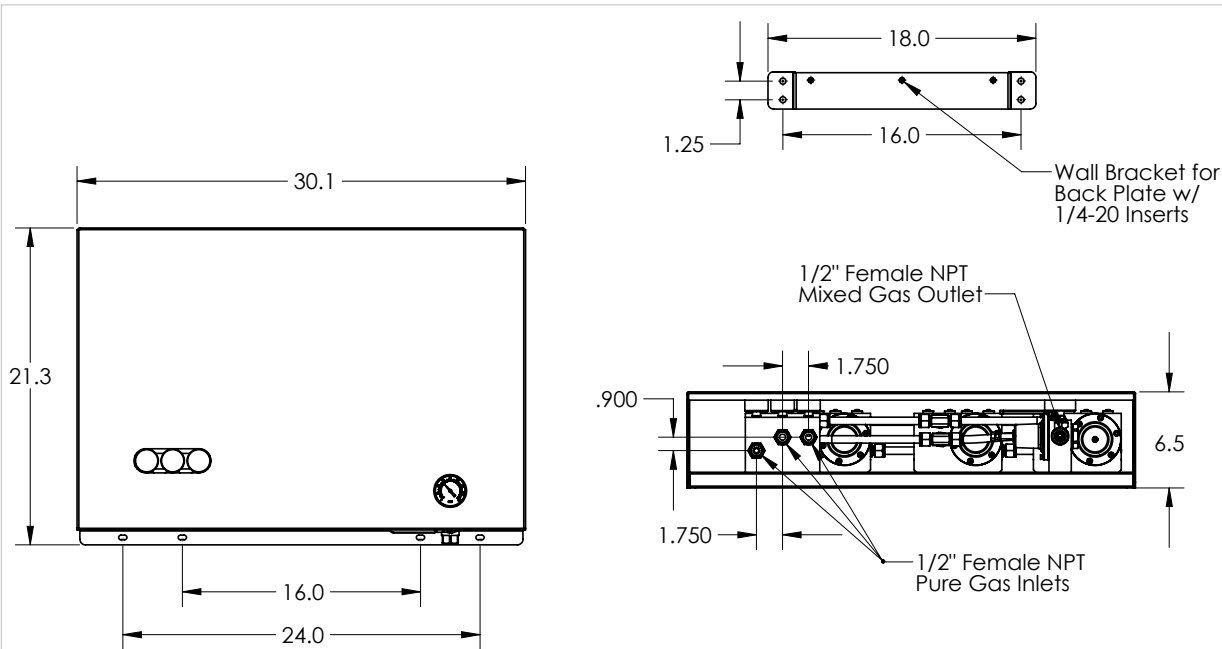

Drawing F

PROPRIETARY AND CONFIDENTIAL
 THE INFORMATION CONTAINED IN THIS DRAWING IS THE SOLE PROPERTY OF MCDANTIM INC. ANY REPRODUCTION IN PART OR AS A WHOLE WITHOUT THE WRITTEN PERMISSION OF MCDANTIM INC IS PROHIBITED.

		UNLESS OTHERWISE SPECIFIED:	NAME	DATE		
		DIMENSIONS ARE IN INCHES TOLERANCES: FRACTIONAL ± 1/32 ANGULAR: MATCH ± BEND ± TWO PLACE DECIMAL ±.01 THREE PLACE DECIMAL ±.005	DRAWN	TRA		9/21/15
		INTERPRET GEOMETRIC TOLERANCING PER: Y14.5M-1994	CHECKED			TITLE:
		MATERIAL	ENG APPR.			TMA-30" DIM
		FINISH	MFG APPR.			Q.A.
NEXT ASSY	USED ON		COMMENTS:			SIZE DWG. NO. REV
APPLICATION		DO NOT SCALE DRAWING				A TMA-4000-3-DIM
						SCALE: 1:8 WEIGHT: SHEET 1 OF 1

5

4

3

2

1

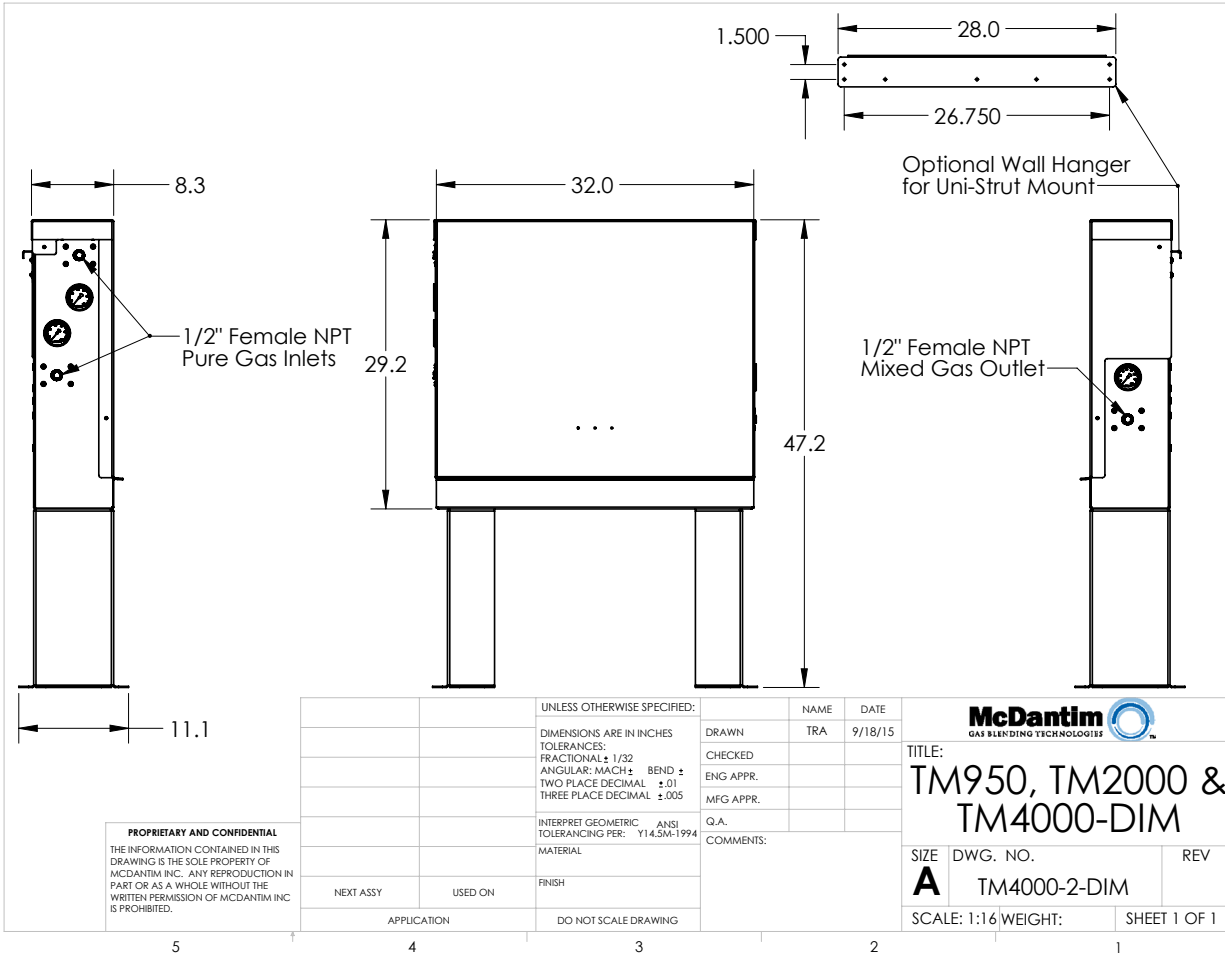

Drawing G

PROPRIETARY AND CONFIDENTIAL
 THE INFORMATION CONTAINED IN THIS DRAWING IS THE SOLE PROPERTY OF MCDANTIM INC. ANY REPRODUCTION IN PART OR AS A WHOLE WITHOUT THE WRITTEN PERMISSION OF MCDANTIM INC IS PROHIBITED.

		UNLESS OTHERWISE SPECIFIED:		NAME	DATE
		DIMENSIONS ARE IN INCHES TOLERANCES:		DRAWN	TRA 9/18/15
		FRACTIONAL ± 1/32		CHECKED	
		ANGULAR: MACH ± BEND ±		ENG APPR.	
		TWO PLACE DECIMAL ±.01		MFG APPR.	
		THREE PLACE DECIMAL ±.005		Q.A.	
		INTERPRET GEOMETRIC TOLERANCING PER: Y14.5M-1994		COMMENTS:	
		MATERIAL			
NEXT ASSY	USED ON	FINISH			
APPLICATION		DO NOT SCALE DRAWING			
				TITLE: TM950, TM2000 & TM4000-DIM	
SIZE		DWG. NO.		REV	
A		TM4000-2-DIM			
SCALE: 1:16				WEIGHT: SHEET 1 OF 1	

5

4

3

2

1